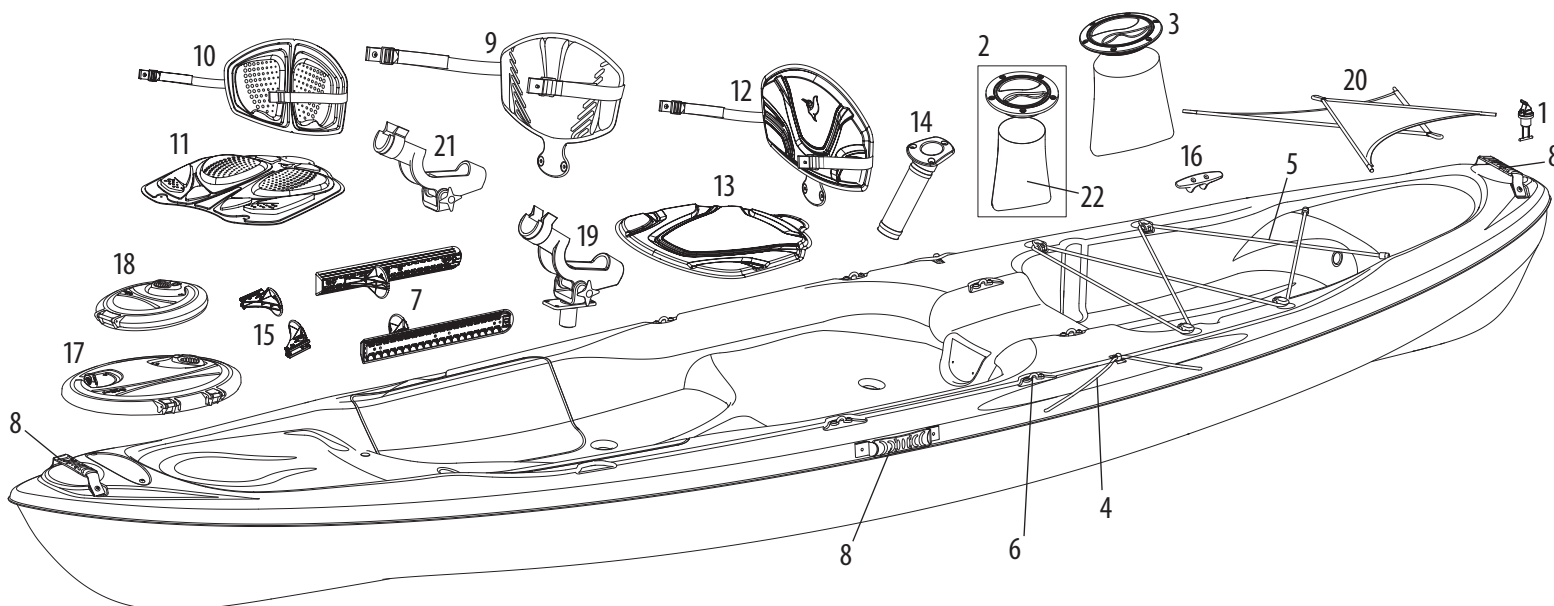

10 and 12 ft (3.05 and 3.6 m) SIT-ON-TOP KAYAKS

KAYAKS À COCKPIT OUVERT DE 3,05 et 3,6 m (10 et 12 pi)

**NOTE:**

Not all models are equipped with the parts listed above.

All accessories are branded Pelican and designed to fit perfectly on your Pelican kayak. For any additional information contact customer service at 1 888 669-6960 or write to us at service@pelicansport.com.

NOTE :

Certains modèles ne sont pas équipés des pièces ci-dessus.

Tous les accessoires sont de marque Pelican et ont été conçus pour s'adapter parfaitement à votre kayak Pelican. Pour toutes informations additionnelles contactez le service à la clientèle au 1 888 669-6960 ou écrivez-nous à service@pelicansport.com.

REPLACEMENT PARTS LIST • LISTE DES PIÈCES DE REMPLACEMENT

- | | |
|--|--|
| <p>1. 11/16 in. (1.75 cm) drain plug • Bouchon de drain de 1,75 cm (11/16 po)
PS0145-2</p> <p>2. 4 in. (10 cm) day hatch with storage bag •
Compartiment de 10 cm (4 po) avec sac de rangement
PS1421</p> <p>3. 8 in. (20 cm) day hatch with storage bag •
Compartiment de 20 cm (8 po) avec sac de rangement
PS0411</p> <p>4. 24 in. (61 cm) paddle tie-down • Porte-pagaie de 61 cm (24 po)
PS1593 PS1668 PS1662
Bright orange Electric blue Yellow green
Orange vif Bleu électrique Citrine</p> <p>5. 90 in. (229 cm) bungee cord • Cordage élastique de 229 cm (90 po)
PS1651 PS1587 PS1709 PS0643
Bright orange Electric blue Yellow green Black
Orange vif Bleu électrique Citrine Noir</p> <p>6. Accessory eyelets • Oeillets de fixation d'accessoires
PS1015-2</p> <p>7. Adjustable footrests • Appui-pieds ajustables
PS0540-2</p> <p>8. Carrying handle - Rubber • Poignées de transport en caoutchouc
PS1365</p> | <p>9. ERGOBAND™ backrest • Dossier ERGOBAND™
PS1474
Grey & blue
Gris & bleu</p> <p>10. ERGOFIT G2™ backrest • Dossier ERGOFIT G2™
PS1769-1-00
Black
Noir</p> <p>11. ERGOFIT G2™ seat for sit-on-top •
Coussin d'assise ERGOFIT G2™ pour cockpit ouvert
PS1740-1-00 PS1740 PS1739
Black Electric blue Bright orange
Noir Bleu électrique Orange vif</p> <p>12. ERGOFORM™ backrest • Dossier ERGOFORM™
PS1562
Black and white
Noir et blanc</p> <p>13. ERGOFORM™ seat • Coussin d'assise ERGOFORM™
PS1860
Black
Noir</p> <p>14. Flush-mount rod holder •
Porte-canne encastré
PS0649-3-00
Black
Noir</p> |
|--|--|

REPLACEMENT PARTS LIST • LISTE DES PIÈCES DE REMPLACEMENT (CONTINUED • SUITE)

- | | | | | | | | | | | | |
|---|---|---|--|--------------------------------|--|---|--|--------------------------------|--|--|---------------------------------|
| <p>15. Footrests • Appui-pieds
PS1082</p> <p>16. Mooring cleat • Taquet d'amarrage
PS0105-P11</p> <p>17. Oval quick lock hatch • Caisson « Quick Lock » ovale
SERIE KW12 / SÉRIE KW12</p> <table border="0"> <tr> <td>PS1596
Bright orange
Orange vif</td> <td>PS1469
Electric blue
Bleu électrique</td> <td>PS1542
Yellow green
Citrine</td> <td>PS1432
Black
Noir</td> </tr> </table> <p>18. Round Quick Lock hatch • Caisson « Quick Lock » rond
SERIE KW10 / SÉRIE KW10</p> <table border="0"> <tr> <td>PS1598
Bright orange
Orange vif</td> <td>PS1470
Electric blue
Bleu électrique</td> <td>PS1595
Yellow green
Citrine</td> <td>PS1433
Black
Noir</td> </tr> </table> | PS1596
Bright orange
Orange vif | PS1469
Electric blue
Bleu électrique | PS1542
Yellow green
Citrine | PS1432
Black
Noir | PS1598
Bright orange
Orange vif | PS1470
Electric blue
Bleu électrique | PS1595
Yellow green
Citrine | PS1433
Black
Noir | <p>19. Swivel rod holder • Porte-canne pivotant
PS3081-00</p> <p>20. Filet porte bagage • Mesh tankwell
SERIE KW12 / SÉRIE KW12 SERIE KW10 / SÉRIE KW10</p> <table border="0"> <tr> <td>PS1838
Bright orange
Orange vif</td> <td>PS1520
White
Blanc</td> </tr> </table> <p>21. Swivel fishing rod holder • Support canne à pêche pivot
PS1262</p> <p>22. Storage bag • Sac de rangement
PS1246</p> | PS1838
Bright orange
Orange vif | PS1520
White
Blanc |
| PS1596
Bright orange
Orange vif | PS1469
Electric blue
Bleu électrique | PS1542
Yellow green
Citrine | PS1432
Black
Noir | | | | | | | | |
| PS1598
Bright orange
Orange vif | PS1470
Electric blue
Bleu électrique | PS1595
Yellow green
Citrine | PS1433
Black
Noir | | | | | | | | |
| PS1838
Bright orange
Orange vif | PS1520
White
Blanc | | | | | | | | | | |

**HOW CAN YOU USE THE PADDLE TIE-DOWN?**

Place the paddle into the molded space located on the side of the kayak, pass the bungee cord over the paddle and attach it to the hook.

COMMENT POUVEZ-VOUS UTILISER LE PORTE-PAGAIE ?

Déposez la pagaie dans l'espace moulé situé sur le côté du kayak, passez le cordon élastique par-dessus la pagaie et attachez-le au crochet prévu à cet effet.

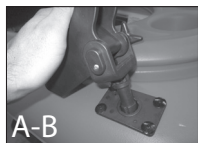
**HOW CAN YOU INSTALL AND SET-UP THE SWIVEL ROD HOLDER?**

- A) Insert the rod holder on the base, align the slot with the groove and slide it through.
- B) Lift up the rod holder and turn it around its axis to the desired position.
- C) To change its angle, loosen the assembly screw and adjust the rod holder to the desired angle.
- D) Secure the fishing rod with the soft latching strap located at the top of the rod holder.

NOTE: The rod holder may vary depending on your fishing kayak model.

COMMENT POUVEZ-VOUS INSTALLER LE PORTE-CANNE PIVOTANT ?

- A) Insérez le porte-canne sur la base, alignez la fente avec la rainure et faites-la glisser.
- B) Soulevez le porte-canne et tournez-le autour de son axe jusqu'à la position désirée.
- C) Pour changer l'angle du porte-canne, dévissez la vis d'assemblage, tournez le porte-canne à la position désirée et revissez la vis.
- D) Fixez la canne à pêche avec la sangle de verrouillage située en haut du porte-canne.

NOTE: Le porte-canne peut varier dépendant du modèle de votre kayak de pêche.